



## **ELECTRICAL ENGINEERING**

Ceramic-to-metal assemblies  
made of FRIALIT®-DEGUSSIT®  
High-Performance Ceramics

[www.friatec.com/ceramics](http://www.friatec.com/ceramics)

# FRIALIT®-DEGUSSIT® HIGH-PERFORMANCE CERAMICS **CERAMIC-TO-METAL ASSEMBLIES**

Physical-technical applications impose high requirements on the materials used. Our ceramic-to-metal assemblies have been optimally designed to meet these challenges.

FRIALIT-DEGUSSIT ceramic-to-metal assemblies combine the excellent properties of each individual material i.e. ceramic and metal into one single component:

- The high-performance ceramic part guarantees electrical insulation and dimensional stability.
- The metal component features electrical conductivity and weldability.
- The hard-soldered ceramic-to-metal joint exhibits mechanical strength and vacuum tightness.

We develop ceramic-to-metal assemblies for high-voltage and high-current applications, as well as for measuring and control technology, industrial applications, reactor construction and research. Our years of experience as a manufacturer of prototypes and standard components guarantee superior solutions to accomplish a variety of tasks.

## **ADVANTAGES**

- Operational safety
- Reliability
- Long service life
- Mechanical strength
- High thermal shock resistance
- Good thermal conductivity
- High electrical volume and surface resistance
- High dielectric strength
- Low dielectric loss at high frequencies
- Low cross section for neutron absorption when used in nuclear technology
- Many ceramic-to-metal assemblies are available with non-magnetisable metal parts





**In collaboration with our customers  
we develop ceramic components  
that meet the highest demands in  
electrical engineering.**

# COMPONENTS FOR VACUUM TECHNOLOGY

New technologies are founded on tradition.  
Manufacturing processes under high vacuum  
challenge materials.



Single feedthroughs made of FRIALIT F99.7



Multiple feedthroughs made of FRIALIT F99.7



Feedthroughs with welded flange made of FRIALIT F99.7

## FEEDTROUGHES

The ultra-high vacuum imposes new requirements on conventional materials and joining techniques. Components made of FRIALIT-DEGUSSIT meet these challenges and show their strength in vacuum applications.

Electrical feedthroughs made of ceramic-to-metal assemblies allow transmission of high currents, high voltages or the smallest measurement signals between the vacuum chamber and the exterior. Ceramics provide reliable separation of areas with different potentials.

The good electrical insulation of the material combined with high mechanical strength is an important requirement for efficient feedthroughs.

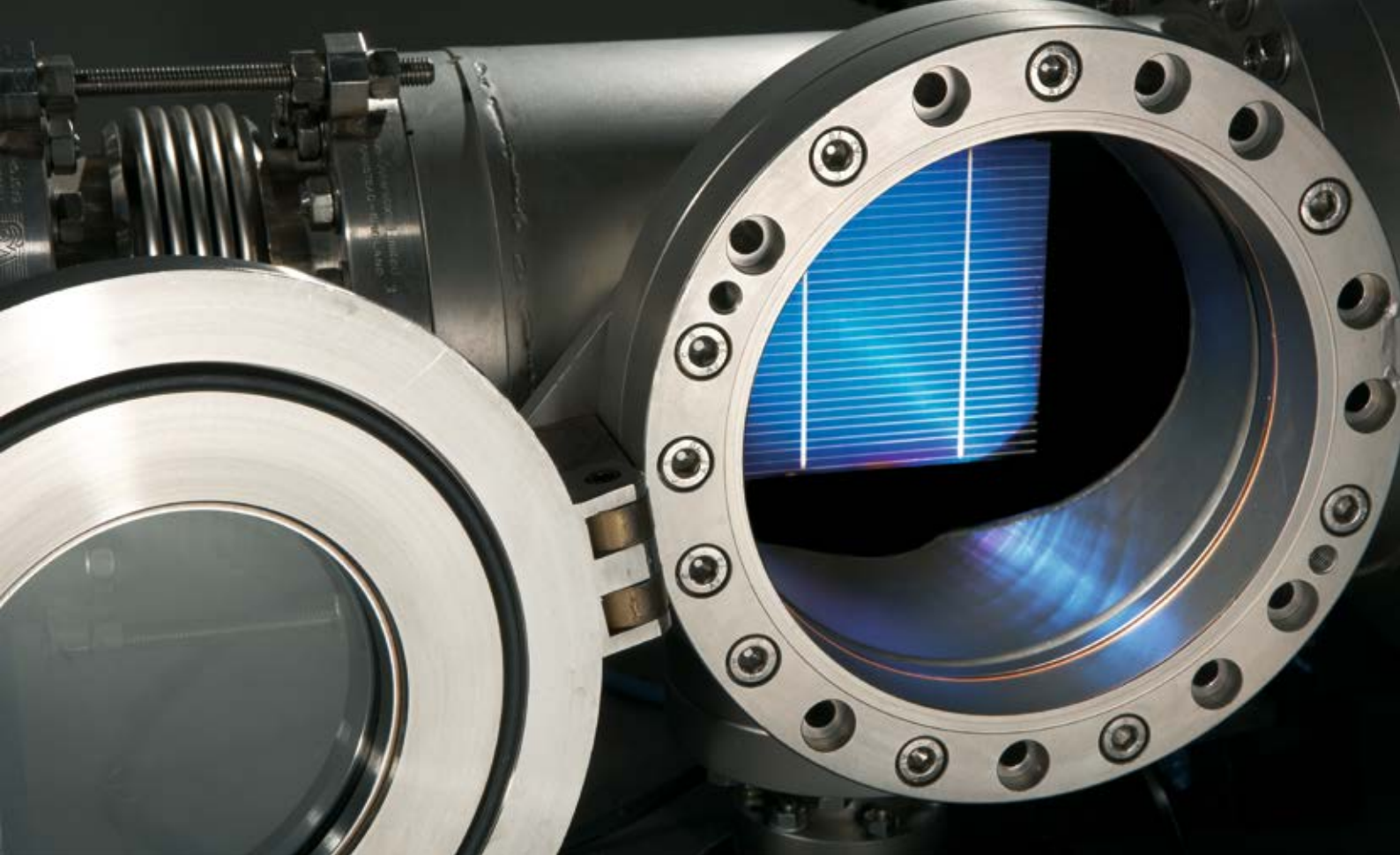

Insulation tubes made of FRIALIT F99.7

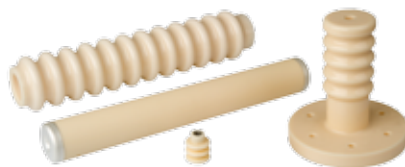

Pin insulators made of FRIALIT F99.7



Tubes, rods and capillaries made of DEGUSSIT AL23

## INSULATORS AND INSULATION TUBES

Insulators and insulation tubes made of FRIALIT F99.7 and FRIALIT F99.7 hf can be fitted with ribs and glazed on the outside. The rib structure increases the creepage distance, leading to higher electric strength when used in atmospheric applications. The glaze facilitates handling and cleaning of the component.

Depending on the construction, our insulation tubes are suitable for cryogenic applications using liquid helium or liquid nitrogen at temperatures ranging from  $-271^{\circ}\text{C}$  to  $450^{\circ}\text{C}$ . Operating temperature:  $580^{\circ}\text{C}$  to  $675^{\circ}\text{C}$  (high temperature). As standard, the insulation tubes are tested for vacuum tightness and can be fitted with different flange types such as CF, KF or COF.

## INSULATION COMPONENTS

Capillaries, tubes and insulating beads ensure perfect electrical insulation in vacuum chambers. They withstand thermal stress and show minimum outgassing rates. Components made of DEGUSSIT AL23 guarantee the best measurement results due to their dimensional stability and excellent insulating properties.

# COMPONENTS FOR **RADIOLOGY AND MEDICAL ENGINEERING**

Because of their excellent properties FRIATEC aluminium oxide ceramics have been used in medical technology for many decades. In both X-ray technology and radiation oncology, ceramic-to-metal assemblies allow reliable diagnoses and safe treatment of the patient.

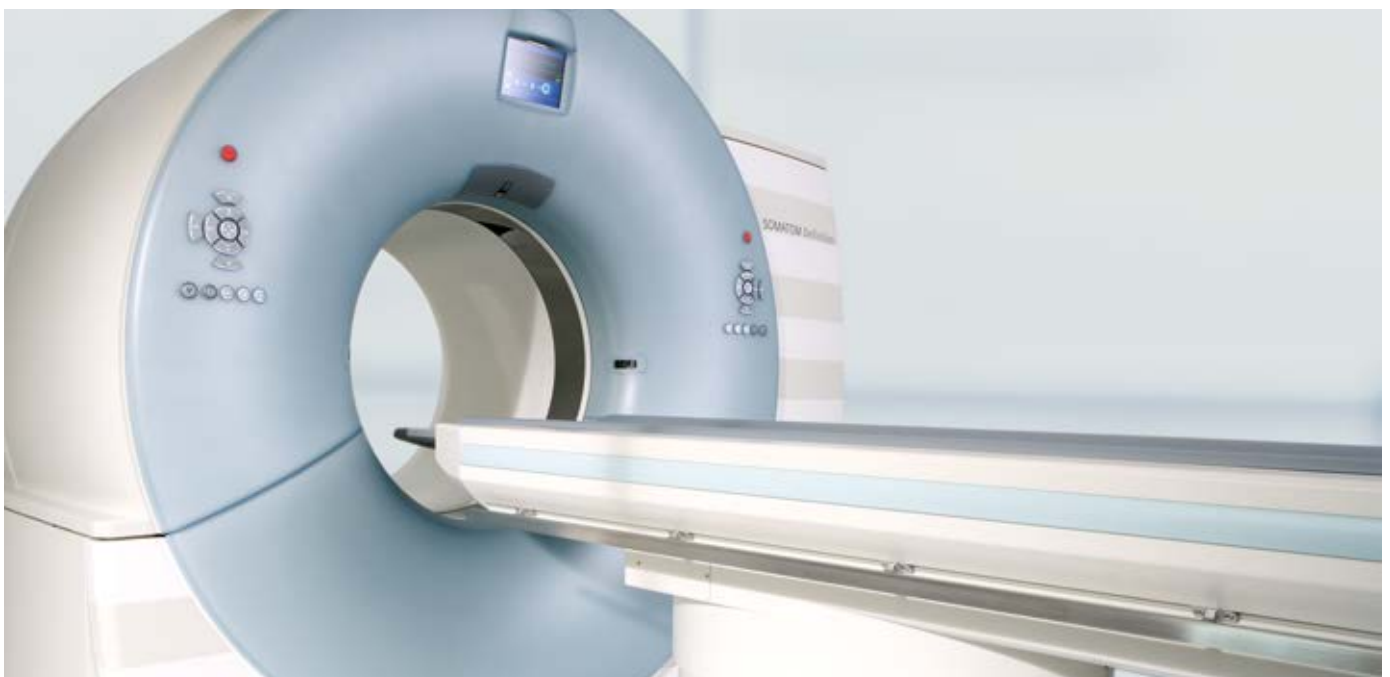



**Precise diagnosis  
with minimum  
radiation exposure**



Rotary piston X-ray tube made of FRIALIT F99.7



Housing for X-ray image intensifier made of FRIALIT F99.7



Anode ceramic made of FRIALIT F99.7

The X-ray tube is the core of computerised tomography. It allows the medical professional to make a precise diagnosis while keeping radiation exposure to a minimum. The X-ray tube and X-ray image intensifier, made of FRIALIT-DEGUSSIT oxide ceramics, are key components and indispensable for modern X-ray diagnostics.

Our oxide ceramic products are the result of decades of experience combined with intense research and development and customised implementation. The X-ray image intensifier using FRIATEC components is one of the most outstanding examples of successful and sustainable collaboration with our customers. The product has been tested

over many years and has proved efficient in practice. It is now used in radiological applications throughout the world. The Heidelberg Ion-Beam Therapy Centre (HIT), designed as the first German institute for clinical radiation therapy and currently the only therapy unit for heavy ions in Europe, relies on our high-performance ceramics.

# COMPONENTS FOR MEASURING AND CONTROL TECHNOLOGY

Our customers expect precise, reproducible measuring results for sensor and measurement applications. Components made of FRIALIT-DEGUSSIT High-Performance Ceramics provide long-term protection for sensitive sensors, even under the most demanding conditions.



Oxygen sensor made of DEGUSSIT FZY



Metallised discs made of FRIALIT FZM



Microwave sensors made of FRIALIT F99.7 hf

## SENSORS

Oxygen sensors with yttria-partially stabilised zirconia DEGUSSIT FZY are suitable for measuring oxygen in gases and atmospheres. They are used for monitoring annealing processes, monitoring protective gas, surface treatment (e.g. in hardening plants), for redox processes, diffusion processes, biotechnological processes and for controlling food packaging. FRIALIT-DEGUSSIT ceramics can be fitted with a conductive coating (MoMn, Ni, Cu, AgPt etc.). The sensors are used in the analysis of

material for petrochemistry, paper industry, gas analysis and other industrial applications.

Level sensors operate more and more frequently with radar or ultrasonic transmitters made of FRIALIT F99.7 or FRIALIT F99.7 hf aluminium oxide. Examples are level sensors used in silos and tanks. Level measurement uses aluminium oxide ceramics as antennas/transmitters of the radar waves, microwaves or ultrasonic waves. The electromagnetic waves emitted are guided along cable or rod probes and

reflected on the surface of the product. Using a connected electronic measurement device, precise measurements of the level inside the container can be obtained, based on the particles time of flight or the frequency change. Adhesives, dust or vapours do not influence the measurement result. This contributes to simple and reliable measurement of liquids, bulk materials and separating layers.





Source: KRONES AG



Flow meter DN 50 made of FRIALIT FZM



Flow meter DN 2.5 made of FRIALIT FZM

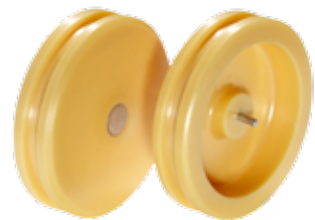

Electrode support made of FRIALIT FZM

## FLOW METERS

In plant engineering, the flow rates of pipelines transporting liquids require precise measurement. Also when filling food, it is essential to determine the exact rate of flow. The electrical conductivity of most liquids is used for electromagnetic flow measurement. This extremely precise measurement procedure can be used in pipelines without causing additional flow resistance. The sleeves of electromagnetic flow meters require an electrically insulating, non-magnetisable

material that is able to withstand high pressure with sufficient mechanical strength and is not corrosive when in contact with aggressive acid or alkaline solutions. The Cermet electrode is unique and patented, a compound made of FRIALIT FZM and platinum. Tested in accordance with pressure equipment standards and tenfold nominal pressure safety, components made of high-performance ceramics can be used without problem under very difficult conditions and enable highly precise filling into any type of tank. Flow meters are designed using

FRIALIT F99.7 and FRIALIT F99.7 hf aluminium oxide and are developed in cooperation with our customers.

## COMPONENTS FOR **SEMI-CONDUCTOR INDUSTRY**

The computer industry is based on microchips. Only high-performance ceramics allow the use of this technology.



## Precision in the $\mu\text{m}$ range



Test plate made of FRIALIT HP79

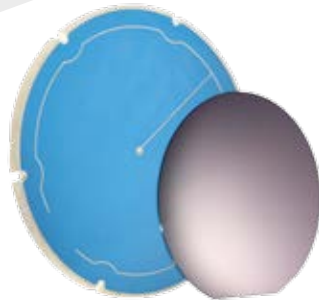

Wafer fixing plate made of FRIALIT F99.7

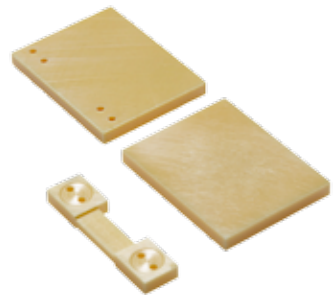

Sensor elements made of FRIALIT FZM

### TESTING

With the trend towards the development and manufacture of even smaller chips, there is no way around FRIATEC products. After all, computer components must be measured and checked in the  $\mu\text{m}$  range before initial operation. Material properties such as high dimensional stability at high temperatures turn our ceramic components into high-precision components.

### POSITIONING

FRIALIT-DEGUSSIT High-Performance Ceramics are used in handling and positioning systems for wafer manufacturing because they are highly resistant to temperature, have excellent electrical properties and are dimensionally stable.

### MEASURING

Minimum outgassing and absorption rates make FRIALIT-DEGUSSIT High-Performance Ceramics ideally suited as distance and sensor elements.

# COMPONENTS FOR **RESEARCH & DEVELOPMENT AND MICROSCOPY**

Focussing units in electron microscopes require tolerances of just a few  $\mu\text{m}$  allowing different specimens from research and technology to be inspected at maximum resolution and depth of field.





**High dimensional stability and best electrical insulation**



Focussing unit made of FRIALIT F99.7

The vacuum system in electron microscopes allows the electron to travel freely without unnecessary scattering caused by collisions with gas molecules and enables efficient use of the electron source. The ultra-high vacuum imposes new requirements that conventional materials are unable to meet.



Insulation component made of FRIALIT F99.7

Focussing units in electron microscopes require tolerances of just a few  $\mu\text{m}$  allowing different specimens from research and technology to be inspected at maximum resolution and depth of field. Minimum leakage and desorption rates are decisive for the functionality of the microscope. Components made of FRIALIT-DEGUSSIT High-Performance Ceramics guarantee best measurement results due to their dimensional stability and excellent insulating properties.



Single and multiple feedthroughs made of FRIALIT F99.7

Components made of FRIALIT-DEGUSSIT oxide ceramics show their strength in vacuum applications. Minimum outgassing and leakage rates at best possible electric insulation and thermal resistance guarantee highest reliability in spectroscopy and microscopy.

# COMPONENTS FOR **PHYSICAL AND MEDICAL FUNDAMENTAL RESEARCH**

Metallised oxide ceramics are the solution for many demanding physical-technical applications. FRIALIT-DEGUSSIT oxide ceramics are therefore indispensable for medical engineering as well as for research and development.

Source: Heidelberg University Hospital / HIT



## Minimum outgassing and absorption rates



Kicker chamber Ø 150 x L 300 mm with TiN coating made of FRIALIT F99.7



Insulator for ion source Ø 580 x L 145 mm made of FRIALIT F99.7



High-voltage insulator Ø 560 x L 450 mm made of FRIALIT F99.7

## PARTICLE ACCELERATOR

FRIALIT-DEGUSSIT oxide ceramics are the ideal material for demanding applications in physical fundamental research, particle physics and materials research. Its material properties meet the very highest demands even under extreme conditions. Vacuum chambers made of FRIALIT-DEGUSSIT High-Performance Ceramics are used in accelerator units. They are used in fast-pulsed bending magnets to contribute to the injection and extraction of particles.

The requirements imposed on components made of oxide ceramics during operation are very demanding. Sufficient mechanical strength and high durability guarantee safe operation. Components made of ceramic-to-metal joints are outstanding due to excellent properties such as maximum electric insulation, absolute tightness even when exposed to extreme pressure and vacuum conditions, exceptional corrosion and temperature resistance at temperatures exceeding 350°C. Unlike metallic parts, ceramic

components prevent the shielding of the rapidly changing external magnetic fields. Ceramics do not heat up when exposed to eddy currents. The additional coating on the inner surfaces of the ceramic chambers, e.g. Ti or TiN, ensures that image currents are reliably discharged and minimises secondary electron emission.

# COMPONENTS FOR **OFFSHORE AND SUBSEA APPLICATIONS**

Oxide ceramics show their advantages under highest pressure: electrical insulation, resistance to pressure, refractoriness and combined with a material-bonded, brazed ceramic-to-metal joint.



High-pressure feedthroughs  $p = 450$  bar made of FRIALIT F99.7



High-current and high-pressure feedthroughs made of FRIALIT F99.7



Level sensor made of FRIALIT FZT



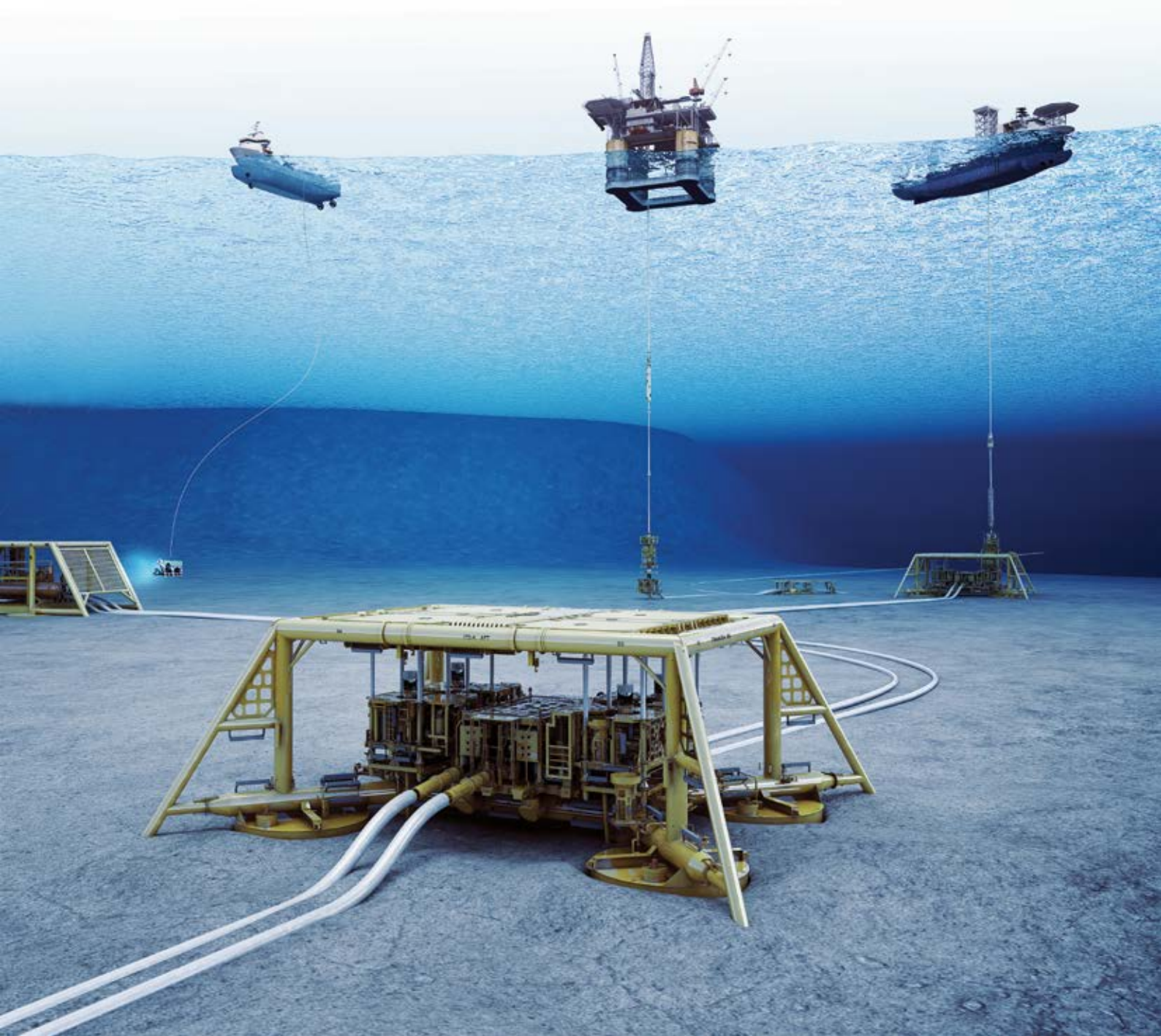

Materials used in offshore and subsea applications are exposed to high pressure and high voltage. Products made of FRIALIT-DEGUSSIT High-Performance Ceramics are the ideal materials and are well suited in this environment.

FRIATEC develops and manufactures the required individual components in cooperation with plant manufacturers. FRIALIT-DEGUSSIT High-Performance Ceramics are produced as material-bonded assemblies using brazing technology and are used

successfully to transmit microwave signals. The filling level of single liquid phases in containers is precisely measured using capacitive sensors. Precise measurement results are decisive for efficient process control.

# TECHNOLOGY

## CONSTRUCTION AND MATERIAL SELECTION

Construction affects approximately 70% of manufacturing costs. As a result, the construction has the task of providing the customer with a product that meets his or her requirements while at the same time ensuring competitive product manufacturing prices.

This means in particular:

- a) Implementation of required property features using simple solutions and standardised primary products
- b) Construction suited to ceramics
- c) Construction suited to production

The choice of ceramic and metal materials suitable for joining requires comprehensive knowledge of application conditions. Table 1 gives an overview of the main requirements imposed on the three constituents of joining, i.e. ceramic, joining area and metal.

Joint constructions are designed in accordance with geometric requirements of the user and the thermal suitability of the selected materials (see Table 3 (p. 21)).

Table 2 shows some basic types of joint constructions which are frequently used for feedthroughs and insulating parts.

The ceramic-to-metal joint is designed in such a way that the metal part, once brazed, exerts compressive stress on the ceramic part. Construction type 1 comes close to the specified target. When it comes to external brazing, metal alloys (Ni42, NiCo 2918) or metals with a coefficient of thermal expansion (CTE) higher than that of ceramics are preferred. These alloys are also suited for internal brazing; however, the CTE of other metals should be lower than that of ceramics. Metals such as copper are an exception, as these materials exhibit a high ductility and are used for internal brazing despite of their high CTE. Adapted alloys or ductile metals with wall thicknesses up to 1 mm are used for external brazing. Larger diameters require the use of moveable shaped parts. If these are magnetisable, e.g. a Ni42 flange of type 1c is subsequently welded to a stainless steel flange (see Figure 11 (p. 26)).

Properties	Main focus on:		
	Ceramic	Joining area	Metal
Electric	Breakdown voltage	■	
	Sparkover voltage	■	
	Creepage distance	■	
	Dielectric constants	■	
	Resistance	■	
Magnetic			■
Thermal	Application temperature		■
	Thermal shock resistance		■
Mechanic	Strength		■
Geometric	Dimensional tolerance	■	
	Surface roughness	■	
UHV tightness	HE leakage rate		■

Table 1: Main requirements

If circumference or internal brazing is required on both ends of a tube, a groove is cut into the ceramic (type 1b). The advantage of this construction is that it keeps brazing equipment to a minimum and allows the individual brazed parts to be mounted easily.

The use of construction type 1 is often limited to brazed diameters smaller than 50 mm when using non adapted metals, because the difference in the CTE of ceramics and metal at brazing temperature is too high. In such cases, construction type 2 is often used.

The same applies when brazing larger metal parts made of austenitic steel via a ductile intermediate copper layer, as this type of construction allows great mobility of the metal parts on the front edge of the ceramic part.

Compact constructions of type 3 are manufactured using adapted metal alloys or ductile metals. The mechanical safety of such a joint is increased by using a ceramic compensation ring of type 3b.

Feedthroughs are exposed to high mechanical stress and require that only compressive stresses occur inside the ceramic. If this construction principle is taken into consideration, highly resistant feedthroughs can be manufactured.







Type	a	b	c
1. Circumference brazing	 internal and external	 with cut-in groove	 with cranked flange
2. Front edge brazing			
3. Flat brazing		 with compensation ring	

Table 2: Basic types of joint constructions

# TECHNOLOGY

## BRAZING TECHNOLOGY

With the exception of some products, usability requires material-bonded and highly vacuum-tight joining of ceramic parts with each other and with metal parts. Various joining techniques can be used to achieve this.

### GLASS BRAZING

Glass brazing is appropriate for gas-tight joining of ceramic components. This joining technique is characterised by a very good general chemical resistance and operating temperatures up to approx. 1,100°C. These joints achieve strength values up to 100 MPa at room temperature (in accordance with DVS German Welding Society, Guideline 3101).

A coefficient of thermal expansion adjusted to the ceramic and the glass braze is decisive for the quality of the glass-braze joint. There is great freedom of design with regard to geometries, however, a suitable braze reservoir and an adequate brazing gap in the construction must be guaranteed. This joining technique is based mainly on the use of glass brazes with a thermal expansion matched to that of ceramics as glass shows no metallic ductile properties.



Fig. 1: Glass-brazed ozone generator



Fig. 2: Curved vacuum chamber with glass-brazed ceramic-to-ceramic joints bending angle: 15°, L 3,200 mm



## BRAZING OF METALLISED CERAMICS

Components made of FRIALIT-DEGUSSIT High-Performance Ceramics are generally metallised using the molybdenum-manganese procedure (MoMn procedure) and subsequent nickel-plating (see Figure 5a). The starting point for this process is a compound of molybdenum and manganese. The compound is applied to the ceramic surface to produce a firmly bonded metallised coating through a firing process. As the majority of commercial vacuum hard solders do not wet the metallised surface, it is nickel-plated using a galvanic or autocatalytic method. The component can be brazed on this base metallised coating.

Metallisation allows for brazing at temperatures above 1,000°C under protective gas atmosphere and/or in the vacuum. A silver-copper eutectic alloy is used as a standard brazing material. Brazing materials with increased melting properties are applied when higher requirements are imposed on the operating temperature, corrosive properties and use of metals that are hardly wetted by the silver-copper eutectic alloy. Table 3 gives an overview of available brazing alloys. Our metallised ceramics are available with galvanic coating such as Au, Ni or Cu to allow for the use of soft solders at low temperatures.

Brazing material	Brazing temperature (°C)
Ag Cu 28	780
Ag Cu 26,6 Pd 5	800 - 850
Ag Cu 21 Pd 25	900
Au Ni 18	950
Cu Ge 10	1,000
Au Cu 65	1,020
Au	1,070

Table 3: Brazing materials and brazing temperatures

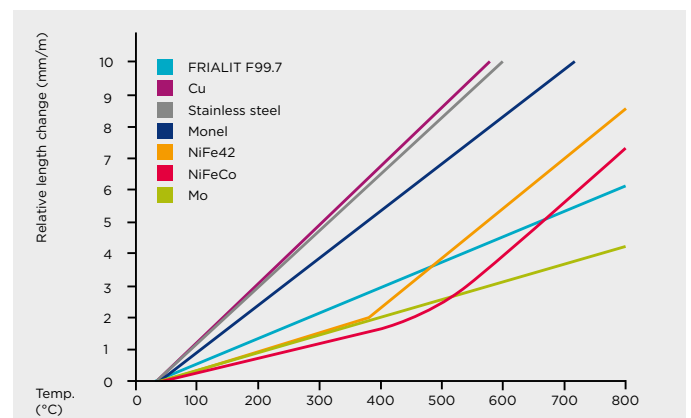

Fig. 3: Thermal expansion characteristics of metallic materials and FRIALIT F99.7 ceramics

# TECHNOLOGY

## BRAZING TECHNOLOGY

Ceramic components prepared using this metallisation process can be hard-soldered with thermally adapted metal components such as NiFe 42 (e.g. VACODIL), NiFeCo (e.g. VACON 10/70), Ti, Mo, CU, etc. Figure 3 shows the coefficients of thermal expansion of different metals compared to that of FRIALIT F99.7.

Figure 4 shows the cross-section of a joining area of a FRIALIT 99.7/AgCu28/1.3917 compound. Tensile tests show that this material combination results in strength values exceeding 100 MPa (in accordance with DVS German Welding Society, Guideline 3101). If the construction is appropriate, these strengths can also be achieved using active brazing.

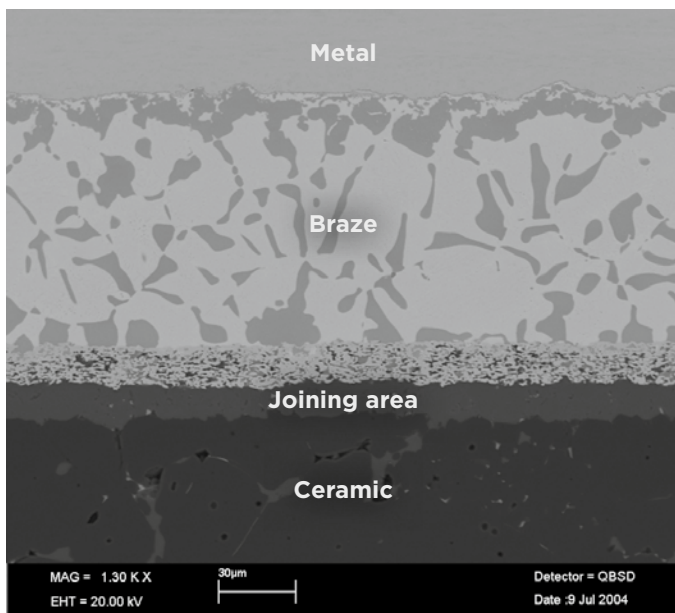

Fig. 4: Cross-section through metallised and hard-soldered Al<sub>2</sub>O<sub>3</sub> ceramic

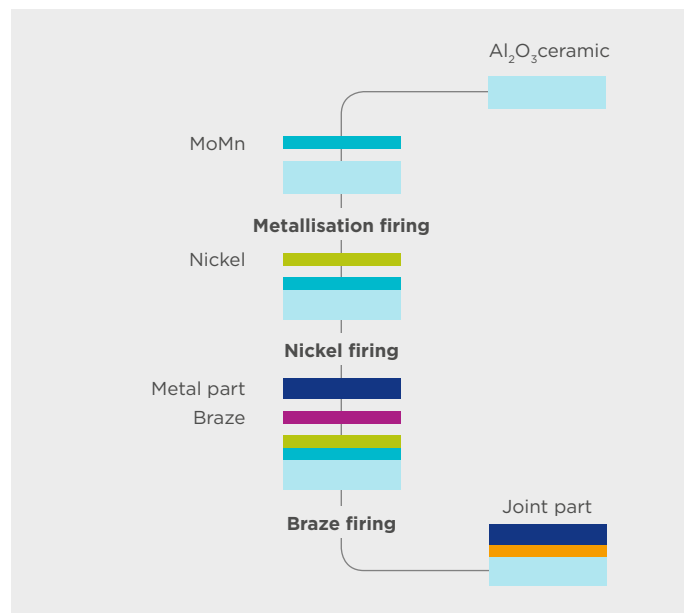

Fig. 5a: Schematic view of MoMn-brazing method

## ACTIVE BRAZING

Active brazing (see Fig. 5b) is based on the use of brazing materials with a low oxygen-reactive metal content such as Ti, Zr, or Hf. They contribute to wetting of  $\text{Al}_2\text{O}_3$  thus eliminating the need for prior metallisation. The strength values of directly brazed  $\text{Al}_2\text{O}_3$  ceramics/Ni42 joints achieve values similar to those of brazed and metallised joints. Figure 6 shows a further example of a joining area of a  $\text{ZrO}_2$  ceramic and steel joint brazed with AgCu26, 5Ti3.

Although active brazing is attractive from a technical and economical point of view, its use with feedthroughs is restricted because the braze does not flow into the brazing gap but remains in the braze deposit. However, these restrictions can be avoided when the constructions take this particularity into consideration.

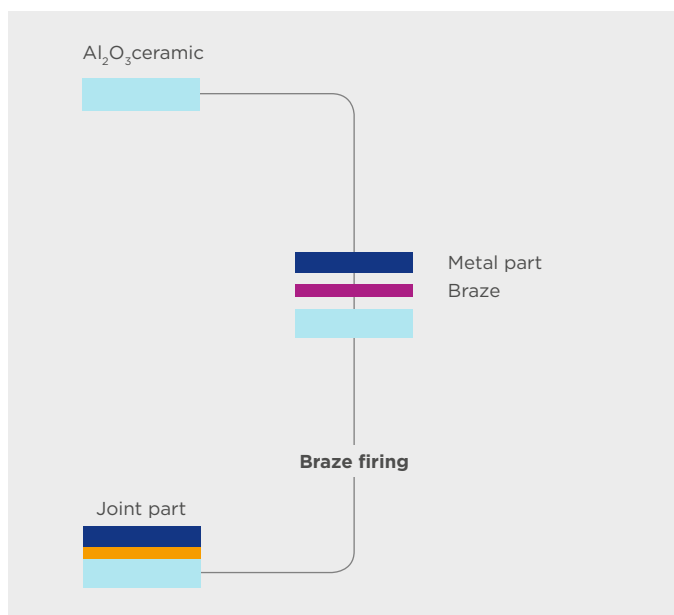

Fig. 5b: Schematic view of active brazing

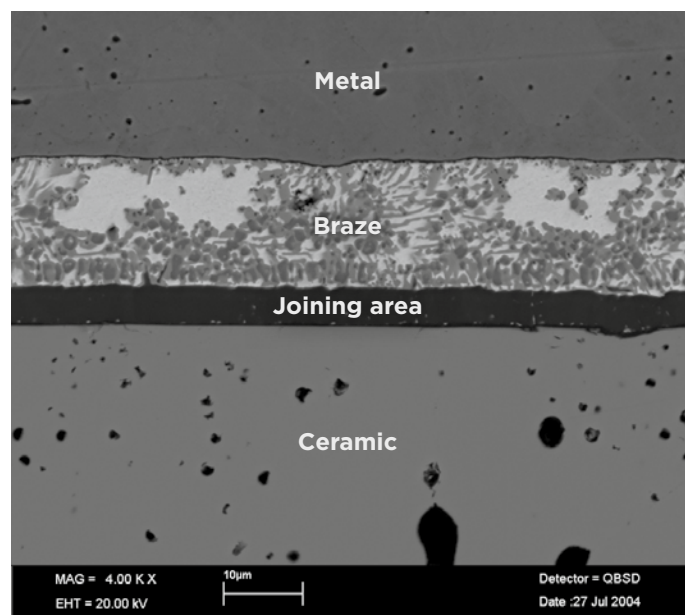

Fig. 6: Cross-section through an active-brazed  $\text{ZrO}_2$  ceramic

# TECHNOLOGY

## OPERATING VOLTAGE AND CURRENT-CARRYING CAPACITY

### OPERATING VOLTAGE

Specification of flashover voltage values refers to the distance between two voltage-carrying electrodes under normal conditions (1,013 mbar, 50% relative humidity) where no flashover occurs. Their values increase 3-4 times in a vacuum of approximately  $10^{-6}$  mbar. High pressures of suitable dry gases or the use of insulating oils can also contribute to such an increase. The values also depend on the electrode geometry. If the ceramic body covers the electrodes, the flashover voltage depends only on creepage distance; the operating voltage can be removed from the diagram (see Fig. 7).

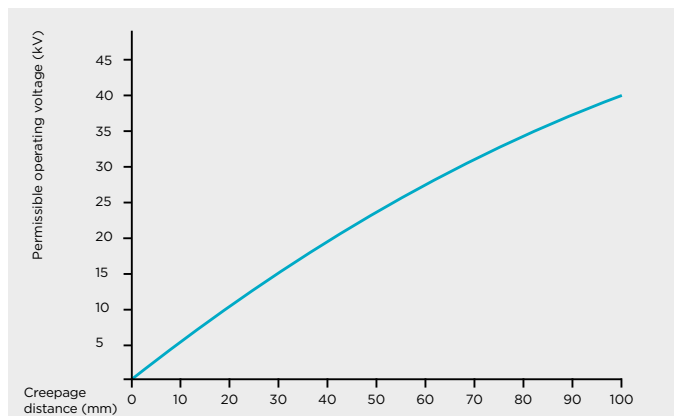

Fig. 7: Permissible operating voltage as a function of creepage distance

### CURRENT-CARRYING CAPACITY

The current-carrying capacity of the feedthroughs depends mainly on the type of conductor used. The specifications in the diagram (see Fig. 8) are intended as general values. In specific cases, heat dissipation of the insulator must be taken into consideration.

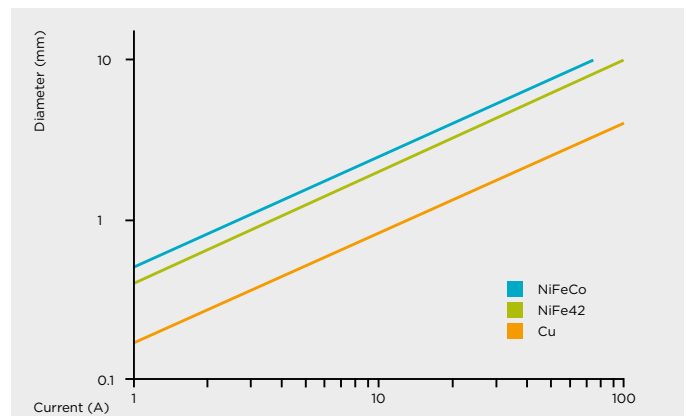

Fig. 8: Current-carrying capacity of different materials as a function of wire diameter



# TECHNOLOGY

## ELECTRICAL RESISTANCE AND BENDING AND COMPRESSIVE STRENGTH

### ELECTRICAL RESISTANCE

When comparing the specific electrical resistance of different insulating ceramics as a function of temperature, highly pure FRIALIT ceramics show very good insulating properties even at higher temperatures (see Fig. 9). While this high electrical resistance (approximately  $10^{14} \Omega \text{ cm}$  at room temperature for FRIALIT F99.7) results to a large extent from the lack of alkali, porcelain and other ceramic insulating bodies contain electric charges which are easy to move. Our ceramic-to-metal assemblies are made of FRIALIT F99.7 material. To avoid the effects of contamination on the surface of oxide ceramics, our ceramic-to-metal assemblies can be given a glaze with high melting points.

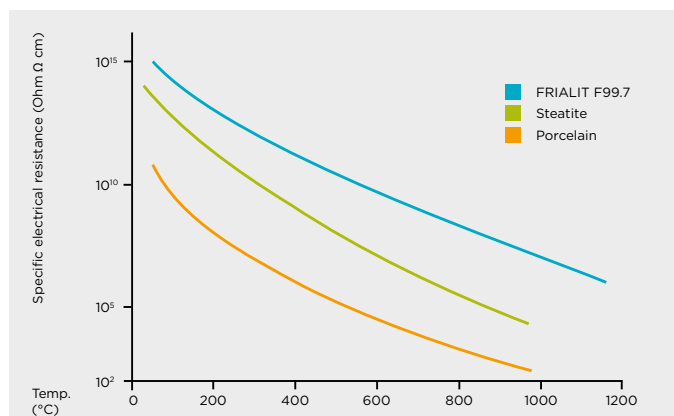

Fig. 9: Specific electrical resistance of different ceramic insulating materials as a function of temperature

### BENDING AND COMPRESSIVE STRENGTH

The compressive strength of FRIALIT ceramics is higher than that of metals at any temperature range. Although lower at room temperature, their bending strength exceeds that of metals above  $700^\circ\text{C}$ . The reason for this behaviour is that the elasticity and fracture limits of ceramic materials coincide and occurring stress cannot be reduced by plastic flow. Unlike metals, our ceramics show no significant loss in strength at higher temperatures (see Fig. 10).

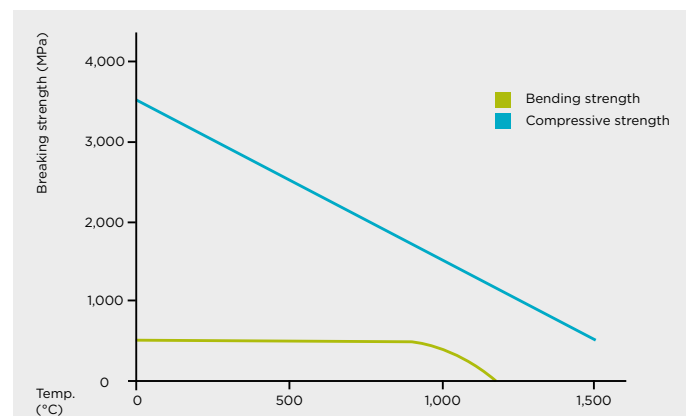

Fig. 10: Bending and compressive strength of FRIALIT F99.7 as a function of temperature

# TECHNOLOGY

## CONSTRUCTION CHARACTERISTICS

### TEMPERATURE RESISTANCE

Hard-soldered metal-to-ceramic joints are particularly suitable for use at higher temperatures up to 600°C in the vacuum or protective gas. Depending on size and design, the thermal shock resistance of ceramic-to-metal assemblies is approx. 180°C. A heating up and cooling down rate of 5°C/min. is a generally accepted reference value.

### CONSTRUCTION NOTES

While installing ceramic-to-metal assemblies made of FRIALIT-DEGUSSIT High-Performance Ceramics, it is important to keep thermal stresses occurring during welding or brazing away from the ceramic-to-metal mating surfaces. This can be taken into consideration by using suitable design, flanges or appliances for heat dissipation.

Ceramic-to-metal assemblies are generally tested with mass spectrometer leak testing using helium as test gas with a sensitivity of approx.  $10^{-9}$  mbar l/sec. External partners are available for compressive strength tests of FRIALIT ceramic-to-metal assemblies. Feedthroughs are exposed to high mechanical stress and require that only compressive stresses occur inside the ceramic. Taking into consideration this construction principle allows for manufacturing of highly resistant feedthroughs.

Unless otherwise indicated, general dimensional tolerances in accordance with DIN 2768 medium (metal) and DIN 40680 medium (ceramics) apply.

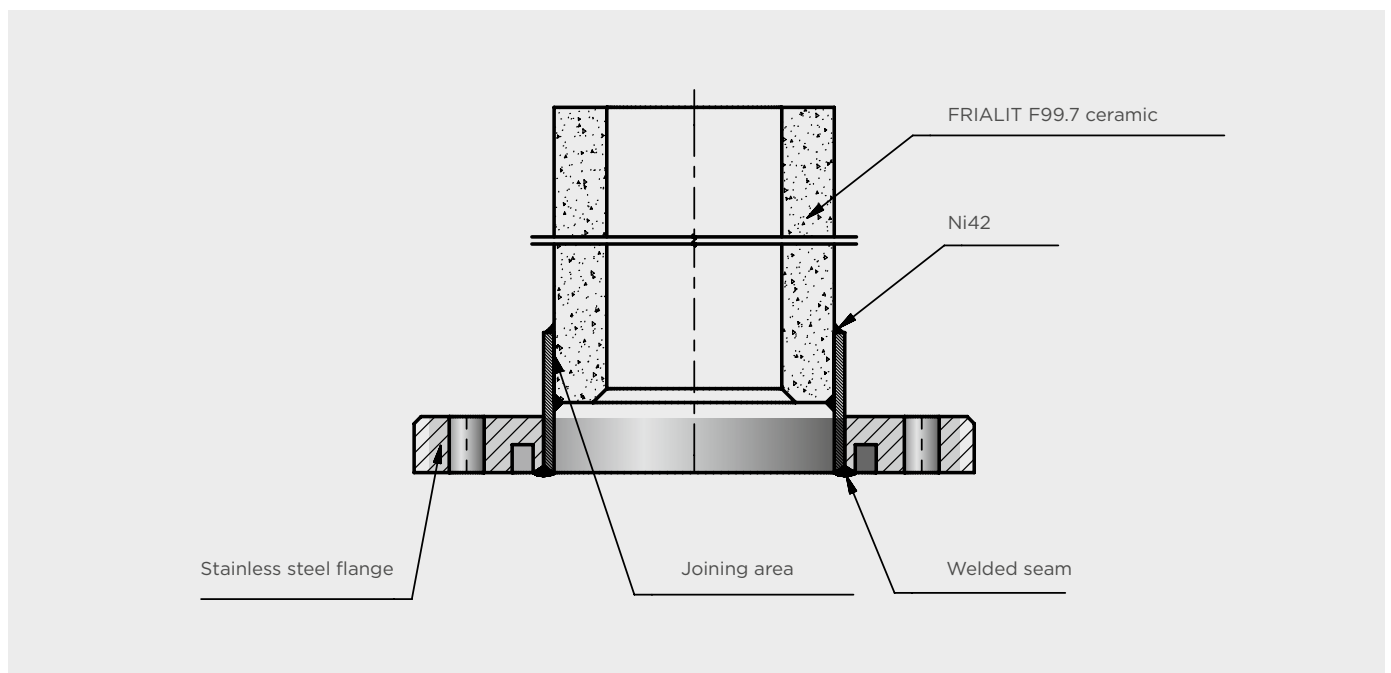

Fig. 11: Example for construction of ceramic insulation tube with flange connection

# TECHNOLOGY

## HINTS FOR HANDLING

### Introduction

Cleanliness is a priority when handling vacuum equipment. The use of clean, lint- and powder-free gloves (vinyl) is recommended at all times. Internal surfaces of vacuum equipment should never be touched without gloves, as fingerprints will contaminate the system.

FRIATEC uses only highly pure materials because raw material manufacturing processes can influence a material's compatibility with vacuum applications.

These hints give you important information about the handling and cleaning of ceramic-to-metal assemblies.

### Hints for ceramic-to-metal components

- Flange-mounting is the preferred method of installation for ceramic-to-metal components. They may also be welded directly to a chamber if a flange connection is not feasible. Please take care to avoid undue stress on the ceramic and the brazing point during the welding process.
- Quality control of ceramic-to-metal components consists of visual, mechanical inspection of dimensions and leak checking, as shown in the production drawing, certificates and inspection protocols.

### Packing

- Protect knife-edges and sealing surfaces with clean plastic flange caps. Alternatively, wrap them in a double layer of PE-foil.
- During transport, fix movable components (for example, bellows and rotating flanges).
- UHV cleaned ceramic-to-metal components are sealed in PE bags with desiccants and/or nitrogen. Alternatively, they can be wrapped in a double layer of PE-foil.

### Parts handling

- Handle clean parts on all vacuum surfaces with clean, lint- and powder-free gloves only (vinyl).

### Avoiding contamination

- Avoid contamination of the components during the assembly and welding processes.
- Mount and weld in a clean room that is separate from the mechanical manufacturing.
- Wear clean, lint- and powder free gloves (vinyl) during the assembly.

### Avoiding stress on ceramic-to-metal components

- Do not expose the ceramic-to-metal components to impact loads, bending or thermal stress.
- Please take care to avoid undue stress on the ceramic and the brazing point during the welding process.

### Welding

- Possible welding methods are:
  - Electron beam and laser welding (we recommend a minimum distance of 5 mm to the brazing point)
  - Metal inert-gas (MIG) and tungsten inert-gas (TIG) (we recommend a minimum distance of 10 mm to the brazing point)
- The minimum distance also depends on the construction and complexity of the ceramic-to-metal assembly. Please contact us for any additional information.
- Alternative cooling methods, e.g. copper clamp to protect the brazing point from too much thermal energy.

### Brazed joints

- Braze joints only under vacuum or shielding gas atmosphere.
- Only if we know the temperature of the subsequent welding processes, can we use the correct pre-brazing material.

### Cleaning ceramic-to-metal components

- Clean in a laboratory washing machine by rinsing with alkaline detergent and deionised water.
- Use an ultrasonic bath with deionised water and alkaline detergent.
- Perform the ultrasonic cleaning cycles (e.g. 3 times for 5 min), interrupted by short rinsing periods (at least 1 min).
- Use clean alcohol (e.g. clean isopropanol or similar) to remove surface water or clean glazed surfaces.
- Dry by blowing off with dry, oil-free compressed air or hot air.
- Bake out up to 250°C (recommended 180°C; rate of temperature 5 K/min).
- Clean vacuum parts that will be assembled into larger units in advance. Clean the parts after mechanical processing, taking into account the UHV cleaning requirements.

# TECHNOLOGY

## MATERIAL PROPERTIES

Properties		Unit	Material FRIALIT F99.7
Main components		-	$\alpha$ - Al <sub>2</sub> O <sub>3</sub>
Purity		wt-%	> 99.5
Density		g/cm <sup>3</sup>	≥ 3.90
Open Porosity		vol.-%	0
Average size of crystallites		μm	10
Bending strength $\sigma_m$	DIN EN 843-1	MPa	350
Weibulls modulus		-	> 10
Toughness $K_{Ic}$	SEVNB	MPa * m <sup>0.5</sup>	3.5
Compressive strength		MPa	3,500
Young's modulus	static	GPa	380
Poisson's ratio		-	0.22
Hardness	Knoop, 100 g	GPa	23
Maximum service temperature	in air	°C	1,950 -
Linear coefficient of expansion	-100 - 20°C		3.6
	20 - 100°C		-
	20 - 500°C	10 <sup>-6</sup> /K	7.3
	20 - 900°C		-
	20 - 1,000°C		8.2
Specific heat	20°C	J/(kg*K)	900
Thermal conductivity	20°C		34.9
	100°C		-
	500°C	W/(m*K)	-
	900°C		-
	1,000°C		6.8
	1,500°C		5.3
Resistivity	20°C		10 <sup>14</sup>
	600°C	Ω*cm	-
	900°C		-
	1,000°C		10 <sup>7</sup>
Dielectric strength	20°C	kV/mm	> 30
Relative permittivity	70 MHz		10
	180 MHz	-	9.9
	30 - 40 GHz		9.8
Dielectric loss tangent	70 MHz		270 * 10 <sup>-4</sup>
	180 MHz	-	150 * 10 <sup>-4</sup>
	30 - 40 GHz		20 * 10 <sup>-4</sup>
Chemical composition	Si <sub>3</sub> N <sub>4</sub> / Al <sub>2</sub> O <sub>3</sub> / MgO	vol.-%	-
Typical colour		-	ivory

The data indicated on this table are in line with the introductory German Industrial Standard DIN 40680 and relate to test specimens from which they were obtained. They are not unconditionally applicable to other forms of the same material. The data must be regarded as indicative only. All data refer to a temperature of 20°C, unless otherwise specified.



Material FRIALIT F99.7 hf	Material FRIALIT FZT	Material FRIALIT FZM	Material DEGUSSIT FZY	Material FRIALIT HP79
$\alpha - \text{Al}_2\text{O}_3$	$\alpha - \text{Al}_2\text{O}_3, \text{ZrO}_2$	$\text{ZrO}_2, \text{MgO}$	$\text{ZrO}_2, \text{Y}_2\text{O}_3, \text{Al}_2\text{O}_3$	$\text{Si}_3\text{N}_4$
> 99.5	> 99.5	> 99.7	> 99.7	-
$\geq 3.90$	$\geq 4.05$	$\geq 5.7$	$\geq 5.5$	> 3.23
0	0	0	0	0
10	5	50	30	-
350	460	500	400	900
$\geq 10$	> 15	> 15	-	15
3.5	3.3	6.3	-	-
3,500	3,000	2,000	2,000	3,000
380	360	185	200	310
0.22	0.24	0.3	-	0.26
20	20	16	17	16
1,950	1,700	900	1,700	1,200
-	-	-	-	1,200
3.6	3.9	-	-	-
-	-	9.3	9.2	-
7.3	7.5	10.4	10.4	-
-	-	10.6	-	-
8.2	8.3	-	10.9	3.2
900	850	400	400	800
34.9	-	3	-	28
-	25	-	2.5	-
-	-	2.3	-	-
-	-	2	-	-
6.8	-	-	-	-
5.3	-	-	-	-
$10^{14}$	-	$10^{10}$	$10^{10}$	$1 * 10^{10}$
-	-	-	$4 * 10^2$	-
-	-	84	-	-
$10^7$	-	-	15	$1 * 10^7$
> 30	-	-	-	-
9.8	-	-	-	-
9.8	-	-	-	-
9.8	-	-	-	-
$3.8 * 10^{-4}$	-	-	-	-
$2.5 * 10^{-4}$	-	-	-	-
$1.4 * 10^{-4}$	-	-	-	-
-	-	-	-	96 / 1 / 3
ivory	white	yellow	white	black

# FRIALIT®-DEGUSSIT® HIGH-PERFORMANCE CERAMICS CERAMIC INNOVATIONS SINCE 1863

FRIATEC manufactures components made of high-performance ceramics according to customer specifications, as well as a comprehensive standard program.

An experienced team of innovative application engineers and resourceful production specialists alongside painstaking quality controls supports our customers in their choice of ceramic material, design and project execution. More than 150 years of experience in the field of ceramic manufacturing and our individual brand of materials, combined with innovative engineering, form the pillars of our company's successful development.

Our products, made of aluminium oxide, zirconium oxide, silicon carbide and silicon nitride, are used predominantly in the following areas:

## ELECTRICAL ENGINEERING

- Single and multiple feedthroughs
- High-pressure feedthroughs for onshore/offshore technology
- Insulation tubes
- Standoffs
- Accelerator components for research and development apparatus
- Sensor components for pressure, temperature, oxygen levels, etc.

## HIGH TEMPERATURE TECHNOLOGY

- Tubes and insulating rods for protection and insulation of thermocouples
- Tubes for gas inlet and outlet
- Grooved and heating tubes for construction of electrically heated furnaces
- Diffusion tubes for the semi-conductor industry
- Multibore tubes
- Crucibles, boats, combustion trays and plates

## MECHANICAL ENGINEERING

- Pistons for dosing pumps (fitted pistons/cylinder units)
- Plungers for high-pressure pumps
- Spacer cans for the chemical industry
- Glide rings, glide bearings, shaft protection sleeves
- Nozzles
- Shaped parts for wear-and-tear use
- Drawing cones and guide elements for the wire industry
- Components resistant to corrosive stress
- Components for the food processing and pharmaceutical industry

## SURFACE FINISHING

- Fine-grinding tools for surface finishing of ultra-hard materials in various shapes and dimensions

# FRIATEC

## INNOVATIVE SOLUTIONS FOR THE GLOBAL MARKET

### INNOVATIONS FOR MORE THAN 150 YEARS

The company was founded in 1863 in Mannheim, Germany, as a brickyard and succeeded in developing its first pathbreaking innovation, chemical stoneware, in 1888. Numerous new developments followed. Among other things, the company started in the mid of the past century processing plastics and combined modern and traditional materials when producing chemical devices and facilities. The following years were characterised by the expansion in the core business and the opening up of more and more new business segments. As Deutsche Steinzeug and later as Friedrichsfeld GmbH, the company, which has been operating under the name FRIATEC AG since 1993, continuously developed to become an internationally active, diversified company.

### SPECTRUM OF INNOVATIVE SOLUTIONS

As such, FRIATEC AG today offers a spectrum of innovative solutions for many industries, e.g. jointing technology for pipe systems, products for water-carrying building services, but also ceramic components which are used in laboratory and electrical engineering but also in medical engineering. With its sophisticated solutions, FRIATEC AG is not only among the most well-known and well-established companies in the metropolitan region Rhine-Neckar but is also one of the global market leaders of its industry.

### PARTNER OF A POWERFUL COMMUNITY

Since 2003, FRIATEC AG has been a member of the ALIAXIS group of companies with headquarters in Brussels. ALIAXIS is the worldwide largest producer of plastic pipe systems for the construction industry, the industry and utilities.

**FRIATEC AG specialises in  
products made of corrosion  
and wear-resistant materials.**

# *Aliaxis*

UTILITIES & INDUSTRY

FRIATEC Aktiengesellschaft - Ceramics Division  
Steinzeugstraße 50 - 68229 Mannheim - Germany  
Phone +49 (0)621 486-1378 - info-frialit@friatec.de

[www.friatec.com/ceramics](http://www.friatec.com/ceramics)



WEBLINK  
Electrical engineering